

HAUL-MASTER



500 LB. SWING BACK TRAILER JACK

WITH 10" TIRE

Model 92372

ASSEMBLY AND OPERATING INSTRUCTIONS

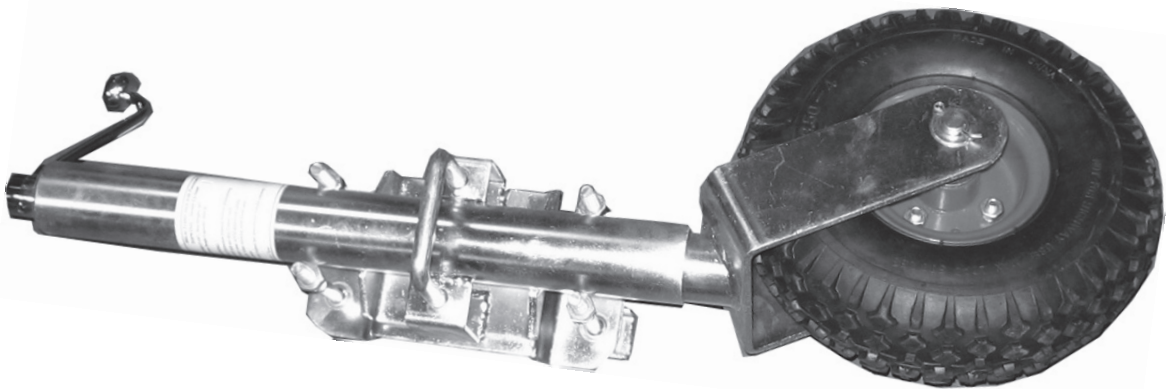

3491 Mission Oaks Blvd., Camarillo, CA 93011
Visit our Web site at <http://www.harborfreight.com>

Copyright© 2004 by Harbor Freight Tools®. All rights reserved. No portion of this manual or any artwork contained herein may be reproduced in any shape or form without the express written consent of Harbor Freight Tools.

For technical questions and replacement parts, please call 1-800-444-3353

Specifications

Weight Capacity	500 Lbs.
Tire Size	10" (Pneumatic)
Tire Pressure	30 PSI
Minimum Height	28- ³ / ₄ "
Maximum Height	39"

Save This Manual

You will need the manual for the safety warnings and precautions, assembly instructions, operating and maintenance procedures, parts list and diagram. Keep your invoice with this manual. Write the invoice number on the inside of the front cover. Keep the manual and invoice in a safe and dry place for future reference.

Safety Warnings and Precautions

WARNING: When using this product, basic safety precautions should always be followed to reduce the risk of personal injury and damage to equipment.

Read all instructions before using this product!

1. **Keep work area clean.** Cluttered areas invite injuries.
2. **Observe work area conditions.** Keep work area well lit.
3. **Keep children away.** Children must never be allowed in the work area. Do not let them handle the Jack.
4. **Store idle equipment.** When not in use, Jacks must be stored in a dry location to inhibit rust. Always lock up Jacks and keep out of reach of children.
5. **Use the right product for the job.** Do not attempt to force a small product or attachment to do the work of a larger industrial product. There are certain applications for which this product was designed. It will do the job better and more safely at the rate for which it was intended. Do not modify this product and do not use this product for a purpose for which it was not intended.
6. **Dress properly.** Do not wear loose clothing or jewelry as they can be caught in moving parts. Work boots, work gloves and work pants are necessary when working. Protective, electrically nonconductive clothes and nonskid footwear are recommended when working. Wear restrictive hair covering to contain long hair.
7. **Use eye protection.** Always wear ANSI approved impact safety goggles.
8. **Do not overreach.** Keep proper footing and balance at all times.
9. **Maintain products with care.** Keep the Jack clean for better and safer performance. The handle must be kept clean, dry, and free from oil and grease at all times.
10. **Stay alert.** Watch what you are doing, use common sense. Do not operate any product when you are tired.
11. **Never work alone.** Always have an assistant nearby to help if unexpected problems arise during use. An assistant can also get help if you are injured.
12. **Check for damaged parts.** Before using any product, any part that appears damaged

should be carefully checked to determine that it will operate properly and perform its intended function. Check for alignment and binding of moving parts; any broken parts or mounting fixtures; and any other condition that may affect proper operation. Any part that is damaged should be properly repaired or replaced by a qualified technician.

13. **Replacement parts and accessories.** When having serviced, use only identical replacement parts. Use of any other parts will void the warranty. Only use accessories intended for use with this product. Approved accessories are available from Harbor Freight Tools.
14. **Do not operate product if under the influence of alcohol or drugs.** Read warning labels if taking prescription medicine to determine if your judgment or reflexes are impaired while taking drugs. If there is any doubt, do not operate the product.
15. **Maintenance.** For your safety, service and maintenance should be performed regularly by a qualified technician.

Warning: The warnings, cautions, and instructions discussed in this instruction manual cannot cover all possible conditions and situations that may occur. It must be understood by the operator that common sense and caution are factors which cannot be built into this product, but must be supplied by the operator.

Specific Trailer Jack Safety Warnings

1. **Roll away.** Avoid situations which allow the trailer to roll away on the caster wheel and trailer wheels. If using the trailer jack on an incline, be sure to chock the wheels. Never leave the trailer unattended while on the jack if the wheels are not chocked.
2. **Swivel failure.** The swivel is very strong and exceeds the stated capacity of the jack. However abuse, corrosion or damage may cause the swivel to break. Regularly inspect the swivel for damage, and discontinue use if the swivel is damaged.
3. **Loose mounting plates or hardware.** Never operate this Trailer Jack if the mounting hardware is not secure on the tongue of the trailer. Regularly inspect the hardware for proper assembly.
4. **Overloading.** Never attempt to lift or support loads in excess of the rated strength of this Trailer Jack. Sudden failure of the Jack may result in serious personal or property injury.

BE AWARE OF DYNAMIC LOADING!

Suddenly dropping a load on the trailer that the jack is attached to may create, for a brief instant, an excess load, which may result in damage to the product and/or personal injury.

5. **Swing up before driving.** Always check to be sure that the Jack is properly swung up into its raised position before driving. Driving with the Jack lowered can cause serious damage to property. **This Trailer Jack is not designed for highway use.**
6. **Dollying on uneven surfaces.** The Tire on this Jack makes moving your trailer without a vehicle convenient. However, moving the trailer on uneven or inclined surfaces can cause personal injury or potential damage to the Jack or other property.
7. **Not to be used for aircraft purposes.**

Unpacking

When unpacking, check to make sure the parts listed on page 7 are included. If any parts are missing or broken, please call Harbor Freight Tools at the number on the cover of this manual as soon as possible.

Assembly / Installation

WARNING: The trailer tongue must be square or rectangular in profile for this Jack to mount properly. A rounded tongue will allow the Jack to rotate to the side causing the trailer to fall suddenly, causing potentially serious personal or property injury.

NOTE: Do not drill holes or otherwise damage the trailer tongue when installing this Jack. Failure of the trailer tongue may result.

NOTE: Installing this Jack is most easily done with the Trailer mounted on the towing vehicle hitch.

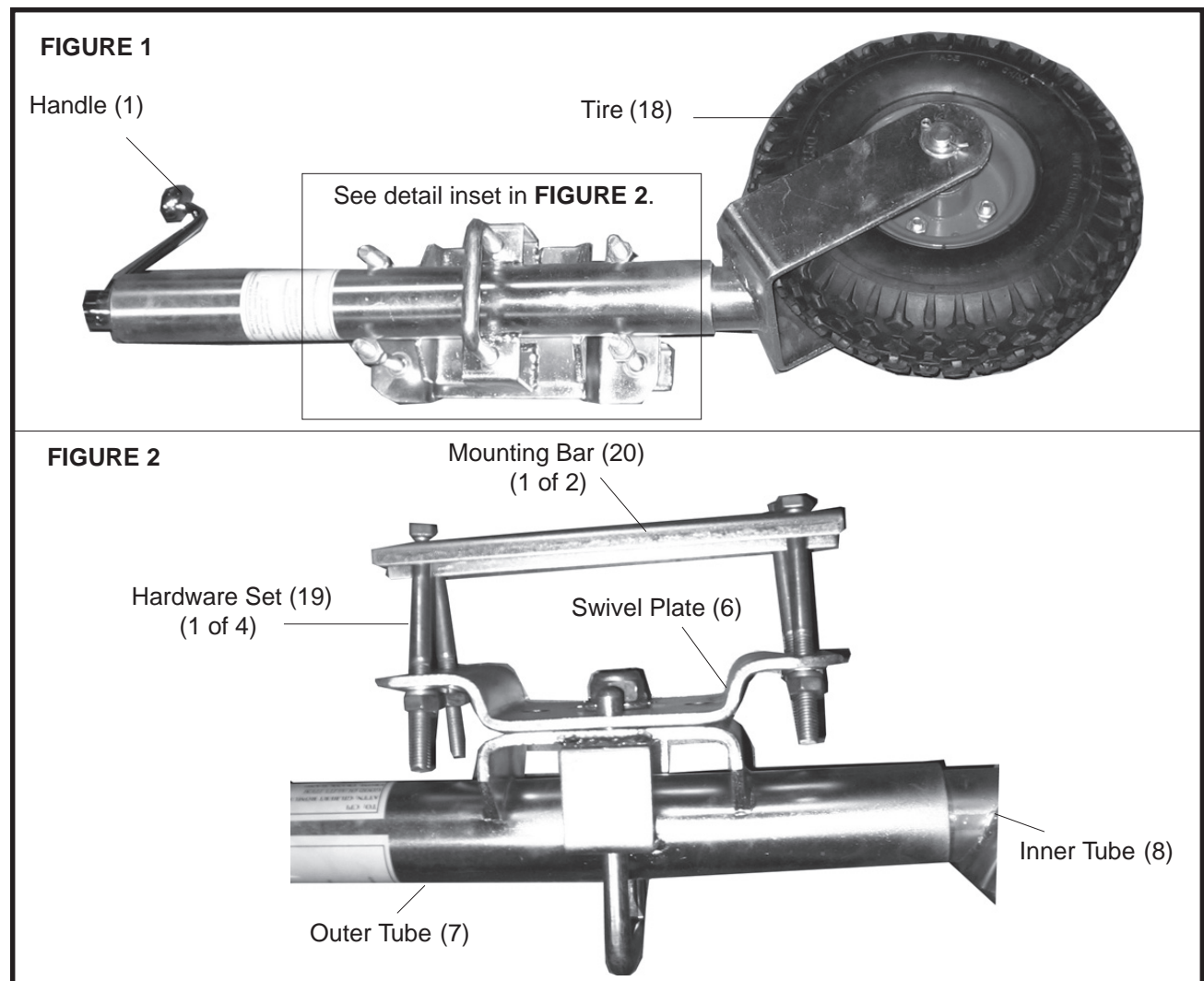

Assembly / Installation (continued)

Refer to **FIGURES 1** and **2** on page 4, and the Assembly Drawing on page 8.

1. Slide the Handle (1) over the Shaft and secure it with the set Screw (2).
2. To mount the Tire (18): Slide the Axle (10) through a Washer (9), the Inner Tube (8) Left Bracket, a Spacer (11), the Wheel, the other Spacer (11), the Inner Tube (8) Right Bracket, and the other Washer (9). Insert a Cotter Pin (12) through the axle on each side, and bend both over completely to secure.
3. Measure the trailer tongue for the best location to mount the Jack. Remember that, while in its storage position, the Jack must not interfere with the Vehicle or trailer when turning or passing over speed bumps, boat ramps, etc.
4. Pull on the Swivel Handle (15) to adjust the Swivel Plate (6), so the Jack is in the lowered position.
5. Hold the Jack against the trailer tongue while using the Jack Handle (1) to lower the Tire (18) to the ground.
6. Using the four Hardware Sets (19) and two Mounting Bars (20), attach the Jack to the trailer tongue. The Mounting Bars must run across (perpendicular) to the trailer tongue. **NOTE:** You may wish to use some removable thread locking compound (not included) on the bolt threads to help secure them.
7. Test the operation of the Trailer Jack. Make adjustments if necessary.
8. Tighten the Hardware Sets (19) firmly and evenly.

Operation

Dismounting The Trailer from The Towing Vehicle.

WARNING: Before dismounting, make sure the trailer wheels are properly chocked to prevent the trailer from rolling. This procedure requires at least 2 people to be present.

1. With the trailer on the hitch, pull the Swivel Handle (15), and rotate the Jack downwards. **WARNING: Keep your fingers away from the Swivel Plate area (See FIGURE 2), and do not allow the Tire (18) to strike your foot as the Jack rotates downward.**
2. Assure that the Swivel Handle pins are in place, locking the Jack into the lowered position.
3. Rotate the Handle (1) counterclockwise to lower the Tire (18) to the ground. Continue to crank just enough for the Trailer Jack to take the weight of the trailer. This will make it easier to disengage the trailer hitch.
4. Disengage the trailer hitch. Remember to disengage any safety chains, electrical connections and other connections between the vehicle and the trailer.
5. You may need to extend the Jack further to clear the trailer hitch. When the vehicle is completely clear, and it is safe to do so, drive the vehicle away from the trailer.

WARNING: Be sure to have 2 spotters watch this operation to be sure the trailer is clear of the vehicle, and that the trailer does not roll away.

Operation (continued)

Using the Jack to Mount The Trailer to the Towing Vehicle.

WARNING: Do not attempt to lift the trailer tongue if it is too heavy for you. You may need assistance for some parts of this operation. This procedure requires at least 2 people to be present.

1. If the trailer tongue is resting on the ground, pull the Swivel Handle (15) allowing the Trailer Jack to rotate downward. **Keep your fingers clear.**
2. If you are able, lift the trailer tongue, while the Jack rotates into the lowered position. If the Tongue is too heavy get assistance.
3. Pull the Swivel Handle (15) out, then reengage the pins, locking the Jack into the lowered position.
4. Rotate the Handle (1) clockwise to raise the trailer to just above the level of the towing vehicle's hitch.
5. Have an assistant spot for you as you move the vehicle close to the trailer. Or, if on smooth ground, roll the trailer to the vehicle.
6. Mount the trailer onto the towing vehicle's hitch.
7. Turn the Handle (1) counterclockwise to raise the Jack slightly off the ground, transferring the trailer weight onto the towing vehicle.
8. Pull out the Swivel Handle (15), and rotate the Jack into its upright position. Be sure that the Swivel Handle locking pins are fully engaged and the wheel chocks are removed before driving away.

Maintenance

If you discover any damage, have all damaged parts repaired or replaced before using your Trailer Jack.

1. Regularly inspect the Springs (17) and Swivel Handle (15) locking pins to be sure they will properly engage and lock the Jack in both the up and down positions. Check all of the Hardware Sets (19) regularly to ensure that they are tight and the Jack is firmly attached to the trailer tongue.
2. Keep the Swivel Plate (6) lubricated with light grease. Inspect it regularly for damage.
3. Keep the crank mechanism (inside the Outer Tube (7)) and the top shaft of the Inner Tube (8) lightly greased. Ensure that this mechanism functions smoothly.
4. Inspect the Tire (18) regularly for damage. Keep the tire filled to a cold pressure of 30 PSI. Keep the axle lightly lubricated.
5. Inspect the entire unit for corrosion which may be caused by exposure to salt water or weather. Rinse thoroughly and re-lubricate promptly after being immersed in salt water.
6. Keep all moving parts lightly lubricated to prevent corrosion. If corrosion develops, you may paint exterior parts of the Jack to help arrest and prevent further damage.

Parts List

Part No.	Description	Qty.
1	Handle	1
2	Screw M8x10	1
3	Bearing	1
4	Screw Rod	1
5	Nut	1
6	Swivel Plate	1
7	Outer Tube	1
8	Inner Tube	1
9	Washer	2
10	Axle	1
11	Spacer	2
12	Cotter Pin	2
13	Washer	1
14	Nut M16	1
15	Swivel Handle	1
16	Bushing	2
17	Spring	2
18	Tire	1
19	Hardware Set	4
20	Mounting Bar	2

PLEASE READ THE FOLLOWING CAREFULLY

THE MANUFACTURER AND/OR DISTRIBUTOR HAS PROVIDED THE PARTS DIAGRAM IN THIS MANUAL AS A REFERENCE TOOL ONLY. NEITHER THE MANUFACTURER NOR DISTRIBUTOR MAKES ANY REPRESENTATION OR WARRANTY OF ANY KIND TO THE BUYER THAT HE OR SHE IS QUALIFIED TO MAKE ANY REPAIRS TO THE PRODUCT OR THAT HE OR SHE IS QUALIFIED TO REPLACE ANY PARTS OF THE PRODUCT. IN FACT, THE MANUFACTURER AND/OR DISTRIBUTOR EXPRESSLY STATES THAT ALL REPAIRS AND PARTS REPLACEMENTS SHOULD BE UNDERTAKEN BY CERTIFIED AND LICENSED TECHNICIANS AND NOT BY THE BUYER. THE BUYER ASSUMES ALL RISK AND LIABILITY ARISING OUT OF HIS OR HER REPAIRS TO THE ORIGINAL PRODUCT OR REPLACEMENT PARTS THERETO, OR ARISING OUT OF HIS OR HER INSTALLATION OF REPLACEMENT PARTS THERETO.

NOTE: Some parts are listed and shown for illustration purposes only and are not available individually as replacement parts.

Assembly Drawing

